

DPT Series Differential Pressure Transmitter

PRODUCT DATA



Application

Differential pressure transmitters are used for acquiring the differential pressure of air in ventilation, air conditioning, and heating plants. The DPT series uses CMOSense technology sensor, which measures the pressure of air and nonaggressive gases with great accuracy and no offset drift. It can measure over- or under-pressure in air ducts in relation to ambient pressure as well as to monitor filters and to control fans and acquire pressure difference between different rooms. It can be widely applied to Air-conditioning and ventilation systems, Building automation, Environmental protection, Fan and ventilation control, Valve and shutter control, Filter and fan monitoring.

Features

- LCD display option
- High reliability & accuracy
- Rapid response
- Pressure range is selectable in one model
- 4~20 mA, / 2~10 VDC Mod-bus RTU output

Specifications

Sensor:	Thermal flow-through principal(1) Piezo-resistive(2)
Signal Output:	4~20mA , 2~10VDC Modbus RTU
Media compatibility	Air, N2, O2
Response time(T1/e)	4.6 ms typical at 12-bit
Linearity and hysteresis	≤ ±1.0% of FS
Repeatability	0.2% of FS
Offset stability	< 0.1% / yr.
Withstand pressure	1 bar
Burst pressure	> 5 bar
Power Supply:	24 VAC/VDC ±10%
Power consumption:	<0.6W (peak value)
Current Output Load:	500 Ohm Max
Warm-up time	Typ. 1s
Working temperature:	0~50°C
Storage	-10°C ~ +70°C

Certification:



Housing Material:

Plastic (ABS)
Flame retarded acc. to UL94-V1

Protection Standard

Room type	IP54
Installation	Wall-mount
Calibration:	Factory calibrated

(1) DPT50/D, DPT100/D, DPT250/D
(2) DPT1000/D

Model Selection

DPT50	-50~50Pa, 4~20mA / 2~10V + Mod-bus
DPT100	-100 ~100Pa, 4~20mA / 2~10V + Mod-bus
DPT250	0~+250 Pa / 0~+500Pa, 4~20mA / 2~10V + Mod-bus
DPT1000	0~+1000Pa / 0~+2500Pa, 4~20mA / 2~10V + Mod-bus
DPT50D	-50 ~50Pa, 4~20mA / 2~10V + Mod-bus, with LCD
DPT100D	-100 ~100Pa,4~20mA / 2~10V + Mod-bus, with LCD
DPT250D	0~+250 Pa / 0~+500Pa, 4~20mA / 2~10V + Mod-bus, with LCD
DPT1000D	0~+1000Pa / 0~+2500Pa 4~20mA / 2~10V + Mod-bus ,with LCD
(a)Temperature error at 0...50 °C 5% of full scale (FS)	
(b)Temperature error at 0...50 °C 2.5% of full scale (FS)	

Appearance and Dimension (Dimension in mm)

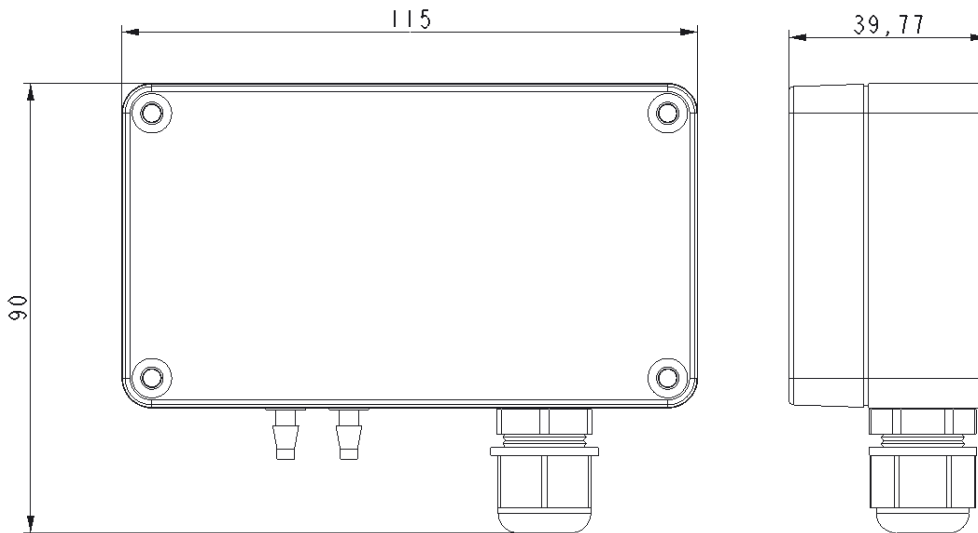

Wiring

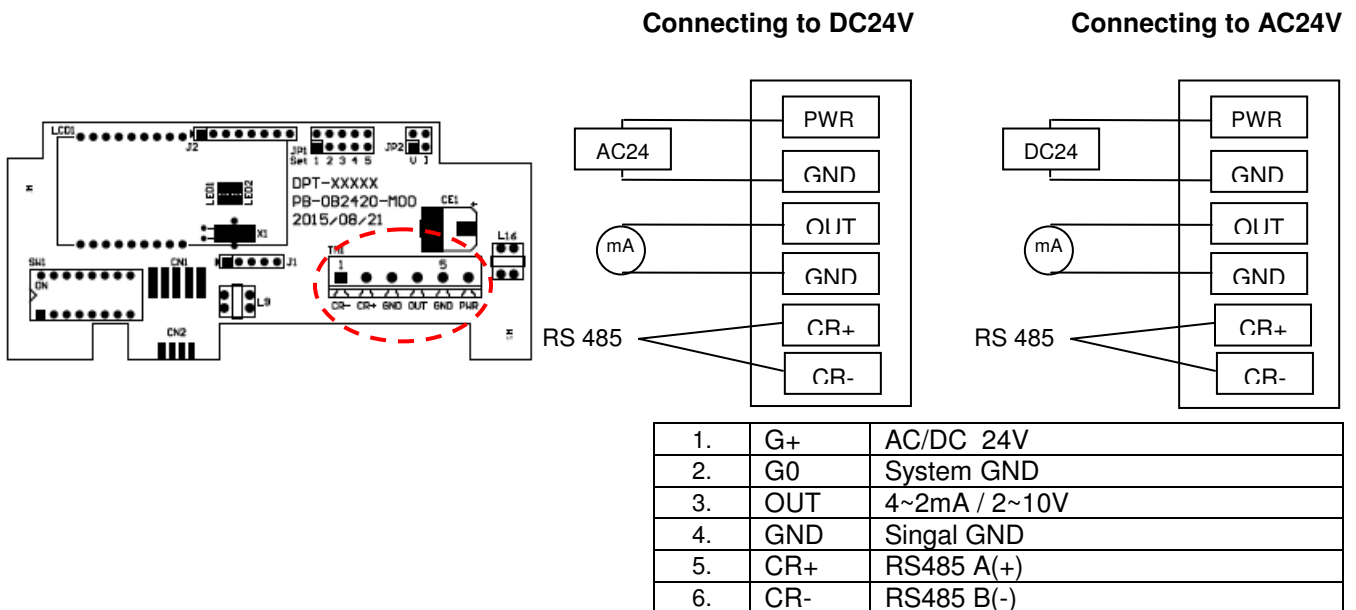

Pressure Range Selection

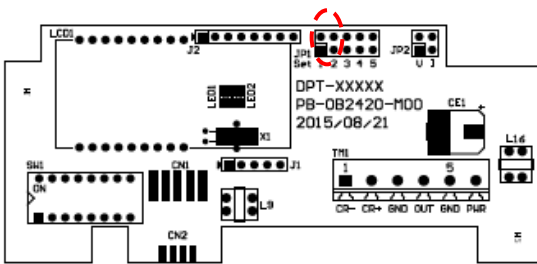



Differential pressure measuring range setting:

JP1-(1,2) is set to "0 1" set differential pressure measurement range from zero to positive pressure

JP1-(1,2) is set to "1 0" set differential pressure measurement range of zero to negative pressure difference

JP1-(1,2) is set to "0 0" set differential pressure measurement ranges from negative to positive pressure difference

Jumper Setting Description

Use the shorting clip to JP1 set measuring differential pressure range, 1: short circuit , 0: Open 

DPT50/ DPT50D		
Range Selection	JP1-2	JP1-1
-50~+50 Pa	0	0
0~+50 Pa(Defaul)	1	0
0~-50Pa	0	1

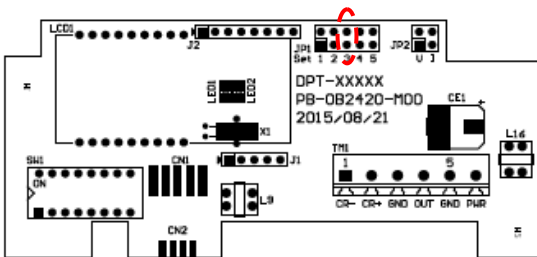

DPT100/ DPT100D		
Range Selection	JP1-2	JP1-1
-100~+100 Pa	0	0
0~+100 Pa(Defaul)	1	0
0~-100Pa	0	1



Differential pressure measuring range setting:

JP1-(3) is set to "0 1" set differential pressure measurement range from zero to positive pressure

Jumper Setting Description

Use the shorting clip to JP1 set measuring differential pressure range, 1: short circuit, , 0: Open 



DPT250/ DPT250D	
Range Selection	JP1-3
0~+250 Pa (Defaul)	1
0~+500 Pa	0

DPT1000/ DPT1000D	
Range Selection	JP1-3
0~+1000 Pa (Defaul)	1
0~+2500 Pa	0

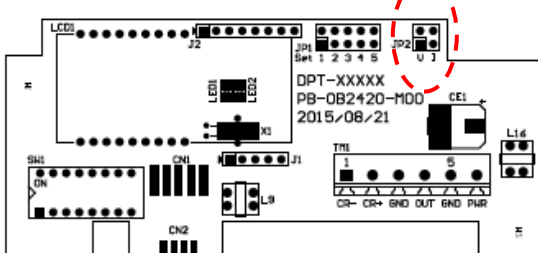
4~20mA / 2~10v Selection



JP2 are used to select 4~20mA / 2~10v linear outputs mode.

Output Configurations	JP2
4~20 mA(Defaul)	
2~10 V	

Device ID Selection

Device ID : Setup device ID with dip switch;

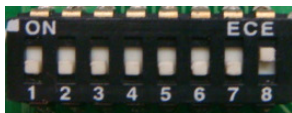
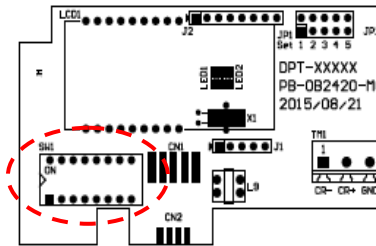
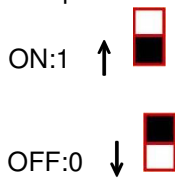

Figure 4

Device ID (ON為1,OFF為0)					
1	0000 0001		64	0100 0000	
2	0000 0010		65	0100 0001	
·	·	·	·	·	·
·	·	·	·	·	·
18	00010010		90	0101 1010	
19	0001 0011		92	0101 1100	
·	·	·	·	·	·
·	·	·	·	·	·
30	0001 1110		100	0110 0100	
31	0001 1111		101	0110 0101	
·	·	·	·	·	·
·	·	·	·	·	·
60	0011 1100		127	0111 1111	
61	0011 1101		128	1000 0000	

Protocol

Baud Rate = 9600 、 Word Length = 8 、 Parity = none 、 Stop Bits = 1 。

Data Reading Type

	Device ID	Function	Address	Data Length	Error Check
Pressure	01	03	0001	0001	XXXX

Responding Data Type

	Device ID	Function	Data byte	Pressure	Error Check
Pressure	01	03	02	02DC	XXXX

**** Remark 1 :**

XXXX is the CRC16 checksum (**Check Sum**) 。

**** Remark 2 :**

Pressure resulting data in hex.

The resulting data is 0x02DC into decimal, ie 732 pa.

Installation

1. Place the lid loosen four screws to remove the cover

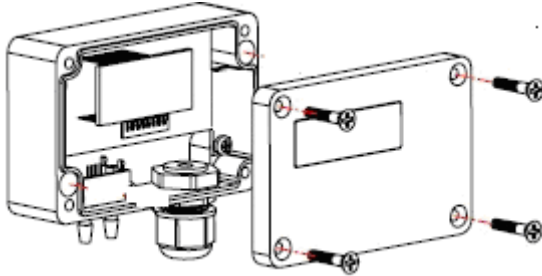

3. Drill two 7mm diameter circular hole in the desire to measure the duct, and in a round hole Drill two 2.2mm screws on each side of the hole to install and fixed guide pressure pipe.

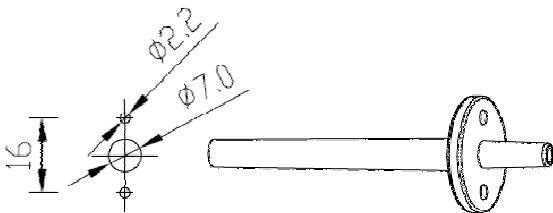

INSTALLATION GUIDE FOR DUCT MOUNT SENSOR OR TRANSMITTER :

- Drilling a mounting hole with diameter 13mm on the duct near measuring point. Insert the probe pipe into duct.
- Unscrew & open the front cover of the product.
- Use enclosed screws to install the wiring box on the duct.
- Lead wire from DDC or PLC panel through opening by using a properly sized screw driver to connect each wire to the terminals of the transducer module according to field wiring diagram.
- Put front cover back and tighten front cover by screw.
- Use a properly sized screw driver to connect the lead wires to the terminals.

2. to screw around on both sides of the diagonal direction, respectively, the body is fixed to the wall. If installed in the concrete wall, you need to match

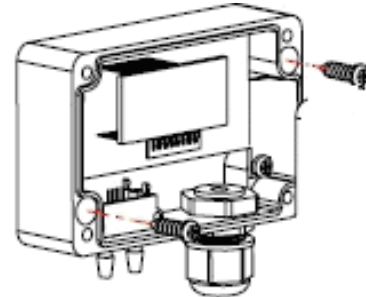

4. Impulse control and measurement of the joint body, with parts in plastic sleeve connection, and according to wiring diagram to connect the signal line (current output, refer to Figure 1). Then screw lock back cover, namely to complete the installation.

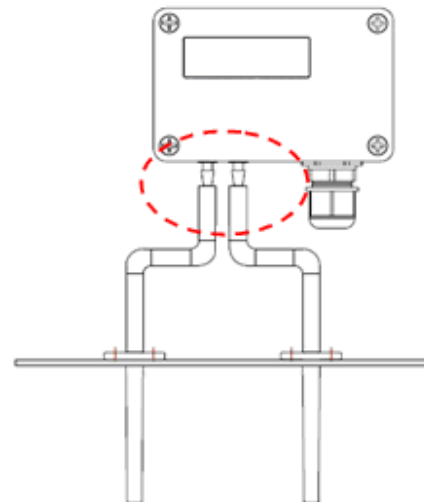

INSTALLATION GUIDE FOR WALL MOUNT SENSOR OR TRANSMITTER :

- Remove the front cover and place the back panel to the desired location.
- Attaching the enclosed screws to the back panel.
- Place the front cover to the back panel.
- Keep the sensor or transmitter away direct sun light, heat source and cold source.
- The recommended location of wall mount sensor or transmitter is 1.5M above the ground.

Note: the documentation may be subject to change without pre-notification